

Technical Regulations 2010

Version 25-June-2009

The Technical Regulations presented in this document were drawn up to serve as directives for the race. Situations that are not covered by the Rules will be decisively resolved at the sole discretion of the jury.

1. General

The rules stipulated herein apply to the Frisian Solar Challenge, hereinafter referred to as the "race".

The rules apply to the race to be held in 2010.

All participants in the race are expected to have read, understood and agreed to the Technical Rules. The organization will penalize all participants and teams that ignore or violate the Technical Rules. Penalization could be meted out in the form of warnings or disqualification and elimination from further participation.

All questions concerning the interpretation of the Technical Rules must be submitted to the organization in writing. The rules will be published on the website and are binding for all participants. If deemed necessary by the organization, she has the right to amend these regulations.

2. Technical condition and safety

All participants are at all times responsible for the technical condition and safety of their vessels during the course of the race. The design must be made such that the vessel can safely participate in the challenge taking into account all aspects of the Challenge (sailing, hoisting storage in the paddock, etc.). Approval of the design and approval during the inspection will under no circumstances exempt the participant of due responsibility.

3. Definitions

- 3.1** Maximum voltage: The maximum voltage, measured in Volts, which is measured with a voltmeter set between any two different points in the electrical system.
- 3.2** Nominal battery voltage: The nominal value of the voltage of the battery.
- 3.3** Dead man's switch: A device that is designed to cut the power supply to the engine as soon as the skipper loses control of the boat or when the skipper leaves the vessel, whether voluntarily or involuntarily.
- 3.4** Battery: The device that is used to store the electrical energy. The following types of batteries for the storage of electrical energy are distinguished in the framework of the race: Lead-acid, Lead-gel, Nickel-Cadmium, Nickel-metal hydride, Nickel-Zinc, Silver-zinc, Nickel-Iron Lithium-ion and Lithium-polymer.
- 3.5** Fully loaded: The condition of the vessel in which all systems have been mounted, all systems have been installed and all systems are operational, all the necessary ballast has been installed and the crew member(s) on board have been issued with the prescribed safety devices.
- 3.6** Freeboard: distance between the waterline in fully loaded condition and an imaginary parallel line that either follows the edge of the deck or a line that connects openings in the side of the vessel, if applicable.
- 3.7** Openings: feed throughs in the main deck or the side of the vessel such as, bilge pump outlets, feed throughs of overboard tubing, feed throughs of cables, etc.
- 3.8** Means of energy storage: Any means, other than batteries, to store energy (e.g. supercapacitors, flywheels, heated water, etc.)

4. Categories

The race is open to three boat categories:

- A. Challenge class vessels with one single crew member (one person challenge class)
- B. Challenge class vessels with two crew members (two person challenge class)
- C. Top class vessels.

Exactly two crew members must be on board of a two-person vessel during the race.

The following are the maximum dimensions per class:

Category	A (1-person)	B (2-person)	C (top class)
Length	6.0 m	8.0 m	8.0 m
Width	2.4 m	2.6 m	2.6 m
Height above waterline	0.7 m	0.7 m	0.7 m

- The length is the overall length from the front end of the vessel up to and including the rear end of the vessel, and including the propulsion system. Exceeding the maximum length by more than 0.5% of the allowed length will result in disqualification.
- The height above the waterline must be limited to the specified height or it must be possible to reduce it to the specified height during sailing. Any mechanism used to adjust variable height must be either manually or electrically operated from the main battery. It is not allowed to install a secondary power source for that purpose.
- No maximum draught is prescribed for the vessels. Participants must however take into account the fact that the depth of the water is limited in certain sections of the route. The actual depth may vary from one month to the next
- Propellers may be changed at all times and in all classes during the course of the race.
- No maximum mass is prescribed for the vessels. Participants must however keep in mind that the boats need to be lugged across dry land in two locations in the course of the race. A maximum of 4/5 members of the team will be allowed to lug the boat (also see rule 5.29 in Chapter 5 "The Vessel").

5. The Vessel

- 5.1** All vessels must be fitted with solar panels, which will serve as the sole source of energy. The use of wind energy and/or energy derived from manpower or animals will not be permitted.
- 5.2** No prescriptions apply to the use of materials with the exception of the following limitations:
- The use of flexible materials that might serve as sails is not allowed.
 - The use of materials that may pollute the environment is not allowed.
- 5.3** The use of energy storage systems, other than batteries for storing electrical energy, is allowed (e.g. flywheels, supercapacitors, etc.). The total onboard energy storage capacity is limited to 1 kWh (=3.6 MJ). This capacity includes the storage capacity of batteries for storing electrical energy.
- 5.4** The skipper must have a clear field of view at all times.
- 5.5** The stability of the vessels must be such that a prescribed rolling moment of 150 Nm applied to the vessel with the vessel loaded with a load of 50 kg at the location of seat of the skipper, will not result in lean over exceeding 12.5 degrees.
- In that case none of the openings in the hull, such as the outlet opening of the bilge-pump(s) or the edge of the deck or any of the solar panels may be submerged below the waterline.
 - In case (additional) floats are being used each of them must have a displacement of at least 50 dm³.
 - It is allowed to use more than one (additional) float on either side of the vessel. In that case the total displacement of the combined floats on either side must be 50 dm³ or more.
- 5.6** As the headroom and width of many of the bridges along the planned route are below the maximum allowed heights and widths, it is allowed to adjust the height and width of the vessels when passing under bridges.
- During those periods the vessels are not required to comply with the stability requirements.

- In the case of the use of electrical energy, the power must be supplied by the solar panels or the main battery.
 - It is not allowed to use an extra energy source for this purpose with the exemption of what has been written in section 7.7.
 - It is also allowed to detach the solar panels from the boat when passing under bridges and over/under other types of obstacles.
 - Where participants opt for the latter action, the fastening system of the solar panels must be designed to ensure due safety during this operation.
- 5.7** All vessels must be fitted with a commercially available and approved dead man's switch that will remain fully functional at all times while the skipper and/or other crew members are on board.
- This will be tested during the evacuation test.
 - During the race any official may ask to test the dead man's switch in his or her presence.
- 5.8** The vessel may not have a closed cabin.
- 5.9** If the vessel is loaded with ballast, it must be fitted into a separate ballast container.
- The container must be designed to ensure that the ballast will be expelled from the container in the case of capsizing (90 degrees heel or more) or such that the container will generate sufficient buoyancy to carry both the ballast and its own weight.
- 5.10** It is mandatory for all vessels to be fitted with one or more electrical and automatic bilge-pumps.
- The pumps must be designed to empty all compartments that house passengers or electrical components.
 - The system must be designed to ensure that each of the above-mentioned compartments can be pumped empty automatically and independently.
 - The pump may be powered by an extra battery.
 - The pump must have a minimum flow rate of 1,500 litres per hour.
 - The pipe(s) that are connected to the pump must have a minimum internal diameter that is no smaller than the pump's outlet.
 - The pipes must be installed such that all bilge water is pumped overboard.
 - If the vessel is a multi-hull design, the pump capacity may be distributed; in other words, a catamaran may be fitted with two pumps, one in each hull, and each with a capacity of 750 l/h.
 - It is not compulsory to install an electrically driven bilge pump in floats
 - Installed bilge pumps must function at all times and the functionality may be tested by officials at all times
- 5.11** All rotating components in or on the vessel must be adequately shielded to prevent unintentional contact.
- This applies both on the water and on land.
 - In the case of the use of a flywheel for power storage purposes, it must be fitted into a protective housing that is capable of containing all released components in the case of disintegration of the system.
 - The latter characteristic must be demonstrated by means of a suitable test or calculation.
- 5.12** All vessels must be designed to ensure that all crew members will be able to evacuate the vessel within 5 seconds without any form of outside assistance.
- The latter characteristic must be demonstrated by means of an evacuation test.
 - The dead man's switch must also be activated simultaneously during the evacuation without having a delaying effect of any nature whatsoever on the evacuation.
 - Hatches that need to be opened before a crew member can evacuate the vessel are not allowed
 - The minimum width of the cabin is 50 cm.
 - When two crew members are sitting next to each other the minimum width is 100 cm.
 - The cabin must have a suitable seat for each crew member.
- 5.13** The use of safety belts is not allowed on board the vessels.

- 5.14** The cabin may not have any potential hazards for the crew members
- 5.15** All fastening systems used on board the vessel must be mechanically secured.
- All connections that may rotate during operation must be secured with the use of a cotter pin.
 - The use of securing means, such as "loctite" is not allowed, except with the special permission of the organization.
 - Permission will only be granted based on a prior written application to the organization with due motivation.
 - The application must also include a design description and a description of the need for the use of this type of securing means.
 - In a bolt and nut connection the thread of the bolt must stick out of the nut with a minimum of two full turns.
 - The same holds for threaded rods.
 - When using self locking nuts the thread must stick out of the plastic ring with a minimum of two full turns.
 - The use of locking washers is advised. The use of washers in bolted connections is compulsory.
 - The use of Velcro is allowed under the condition that this has been clearly indicated in the design and approved by the technical committee prior to the technical inspection.
 - The technical committee may ask additional connections to be installed at all times, especially when it concerns the solar panels or items that influence the safety of the crew members or the operation.
- 5.16** All vessels must be designed with a minimum freeboard of 25 cm over the first 2 m measured from the front end of the vessel and a freeboard of at least 20 cm over the rest of the vessel.
- Both freeboards must be determined in fully loaded condition.
 - Fully closed hulls are exempted from the minimum freeboard of 25 cm over the first 2 m measured from the front end of the vessel.
 - See also the requirements stated in rule 5.17
- 5.17** All vessels must be designed to be capable of generating sufficient buoyancy under full load.
- In this context 'sufficient' is defined as the capacity required to carry the complete construction with the crew member(s) with a reserve capacity of 20%.
 - The latter capacity must be demonstrated by means of a calculation and a weighing.
 - In addition, the vessel must also be designed such as to ensure that it is incapable of sinking the moment it fills up with water.
 - In the case of the occurrence of the latter situation, it may be assumed that the crew members will not be on board any more.
- 5.18** All vessels must be fitted with a fastening point for a towline (catamarans must have a fastening point on each hull).
- The fastening point(s) and its supporting structure must be capable of holding a minimum load of at least twice the vessel's own weight.
 - The minimum internal diameter of the fastening point(s) must be 20 mm.
 - All vessels must be provided with a floating towline of a minimum length of 10 m and a minimum diameter of 8 mm.
 - Catamarans must be fitted with two floating towlines, of a minimum length of 10 m and a minimum diameter of 8 mm, one attached to each of the two hulls.
 - Towlines may not be manufactured with steel wire or any other type of material that is hard to cut in the case of an emergency situation.
 - The towline(s) must be attached to the front of the hull(s)
- 5.19** All vessels must be fitted with a minimum of two types of signalling systems
- An uniformly coloured orange or red warning flag with a minimum size of 30 x 30 cm attached to a stick or similar structure with a minimum length of 1 m
 - An audible warning system, such as a ship's horn audible at reasonable distance, e.g.

- An orally operated horn
 - A horn operated by a compressed air bottle
 - An electrically operated horn
- 5.20** All vessels must be fitted with a clearly visible marker buoy that is permanently connected to the vessel via a rope with a minimum length of 5 m
- The connection and storage of this buoy must be such that when the vessel disappears under the water surface the buoy starts floating on the water surface and thereby indicates the position of the vessel
- 5.21** All vessels must be fitted with at least one paddle with a minimum length of 60 cm, a minimum blade length of 30 cm and a minimum blade width of 13 cm.
- The paddle must be fastened and sealed in an easily-accessible location on board the vessel.
 - The paddle will be sealed by an official of the technical committee.
 - The paddle may exclusively be used in emergency situations or with the permission of the organization.
 - Following the use of the paddle, it must be refastened in the allocated location and resealed.
- 5.22** All vessels must be fitted with an approved fire extinguisher with a minimum capacity of 1 kg of extinguishing material suitable for extinguishing fires, including electrical fires (category E).
- Due to the fact that it is hard, if not impossible to find category E extinguishers, participants are also allowed to use category A (solid materials) fire extinguishers.
 - Only fire extinguishers showing a valid approval are allowed
- 5.23** All vessels must be equipped with a pitch hook with a minimum length of 1 m and a non-metallic hook
- 5.24** The vessels must be equipped with a life jacket for every person onboard the vessel. The capacity of the life jacket must be sufficient for carrying the weight of the person wearing it
- 5.25** In the case of the occurrence of a (technical) failure on board, the participants are entitled to repair and/or replace the failed or flawed components with identical ones.
- Wherever possible this must be done under the supervision of the organization.
 - In the case of major repairs/replacements, e.g. in the case of the replacement of a battery, the organization will determine the need for a time penalty.
 - All repairs to the vessels' electrical systems must be reported to the organization in advance.
 - Repairs to other parts of the vessels must be reported subsequently.
 - Replacement or recharging of batteries will result in the issuing of a time penalty of one minute for the next stage for each percentage point of the allowed maximum battery mass. Stages that have already been started will be counted as complete stages (e.g.: installing a new lead-acid battery of 10 kg or recharging it during or after the second stage will yield a time penalty of $10 \text{ kg}/25 \text{ kg} \times 100\% \times 1 \text{ minute} = 40 \text{ minutes}$ for the third stage).
 - If a battery is changed or recharged during the last stage the time penalty will be given for the last stage
 - Modifications to the vessel are not allowed after the vessel has been technically approved by the technical committee
 - Modifications demanded by the organisation however must be incorporated before the given deadline
 - While performing a modification, participation in the race is suspended until the modification has been inspected and approved
- 5.26** All vessels must be fitted with four lifting hook eyes with a minimum inner diameter of 20 mm.
- The lifting eye hooks must be made out of solid metal, e.g. no ropes or chains
 - The lifting eye hook and the supporting structure must be designed and manufactured such that each of the individual lifting eye hooks can carry the full weight of the vessel

- The hook eyes must be positioned such as to make it possible to lift the vessel, with the installed solar panels, in and out of the water.
 - The longitudinal distance between the lifting hook eyes is between 1 and 4 m
 - In the latter situation the vessel must remain horizontal to the greatest extent possible.
 - A maximum deviation of 10 degrees from the horizontal position is allowed.
 - The structural integrity of the vessel must not be compromised during hoisting.
- 5.27** The average speed of the vessels in the challenge classes must be at least 8 km/h. The average speed of the vessels in the top class must be at least 12 km/h. This will be tested during the prologue to the race. During the prologue a distance of 10 km will have to be sailed.
- 5.28** All sharp edges of the vessel must be adequately protected
- 5.29** During lugging from waterway to waterway, one person challenge class vessels and top class vessels may be lugged by no more than 4 people. It is allowed to use auxiliary systems to lug the boat across obstacles provided those systems are carried on board and are included in the boat's official overall weight. Two person challenge class vessels may be lugged by 5 people. It is not allowed to change the lugging team during any given lugging procedure.
- 5.30** The steering gear of the vessel must be sized for adequate controllability, must operate smoothly and be free of play both in loaded and unloaded condition.

6. Solar panels

- 6.1** All participants in challenge classes are bound to fit their vessels with the solar panels provided by the organization, namely the solar panels loaned by the sponsors. Participants in the one person challenge class are provided with five panels each with peak capacities of approximately 175 Wp, and participants in the two person challenge class are provided with six panels on loan. The technical specifications for the panels will be made available on the Frisian Solar Challenge website.
- 6.2** No prescriptions apply with respect to the area of the solar panels used in the topclass as long as they do not exceed the maximum size of the vessel given in section 4 of these regulations.
- The maximum power output of the solar panels is limited to 1750 Wp.
 - Participants are required to submit a drawing and calculation of the power of the solar panel during Step 3 of the design process to enable the technical committee to unambiguously determine the total power output of the solar panel.
 - This calculation must be based on the technical data sheet as supplied by the manufacturer (no supplier brochure) where the power output is reported.
 - The data supplied by the manufacturer must be in accordance with IEC 61215, terrestrial application in standard test condition (STC) for Silicon solar cells.
 - For other than terrestrial Silicon solar cells the power output has to be reported on the basis of the outcome of a measurement performed in accordance with IEC 1829. During the technical inspections a check on the total power output may be performed.
- 6.3** The solar panels must be placed horizontally on all vessels.
- The maximum deviation from the horizontal position is 10 degrees.
 - This also holds for the maximum deviation from the horizontal position for curved solar panels.
 - The use of adjustable systems is allowed provided they are operated manually or on electrical energy derived from the solar panels or the main battery.
- 6.4** Each applied solar panel must be mechanically secured to the vessel, either in a frame or otherwise.
- The design of the fastening system must be such that it will be wind-resistant in all directions, including, turbulence and gusts.
 - All parts of the solar panel sticking out of the hull as well as the frames used to attach the solar panels must be provided with protection of sharp edges

7. Electronics

The type and mass of the battery pack will be evaluated during the technical qualification.

- 7.1** The vessels may be fitted with a battery pack with a maximum nominal capacity of 1 kWh (=3.6 MJ). All further references to the battery pack will refer to the 'main battery'. The nominal capacity is based on a discharge time of 20 hours. To be able to properly judge this requirement, the figures in the list below are used to evaluate the different types of batteries. The battery pack will be weighed during the technical inspection in order to determine whether the battery capacity exceeds the maximum allowed values.

Lead-acid and lead-gel batteries	25.0 kg	(40 Wh/kg)
Nickel-Cadmium	20.0 kg	(50 Wh/kg)
Nickel-metal hydride	14.3 kg	(70 Wh/kg)
Silver-Zinc	8.0 kg	(125 Wh/kg)
Nickel-Zinc	15.2 kg	(66 Wh/kg)
Nickel-Iron	20.0 kg	(50 Wh/kg)
Standard Lithium-Ion	7.1 kg	(140 Wh/kg)
Lithium-Polymer	6.0 kg	(167 Wh/kg)

If a participant decides to install a different means of energy storage the total storage capacity is limited to 1 kWh.

- 7.2** Participants found to have installed a means of energy storage in excess of the maximum allowed levels will be issued a time penalty.
- The time penalty consists of 1 minute per remaining stage per percentage point of the excess amount of allowed maximum battery mass.
- 7.3** A properly functioning Battery Monitoring System is mandatory for all batteries other than lead-acid and lead-gel batteries.
- The system must monitor both the battery's voltage and temperature, and must also be capable of shutting the system down when necessary.
 - For Lithium-Polymer batteries the monitoring of both charge and discharge currents is required. A means of controlling too high currents must be installed.
 - The Battery Monitoring System must be designed to monitor all individual battery panels.
 - The mass of the Battery Monitoring System is not incorporated into the battery mass while determining the battery mass.
 - The participants must make sure that the batteries can be weighed separately.
- 7.4** The maximum allowed voltage is 52 V DC or AC RMS. Only the maximum open circuit voltage of the solar panels may be higher.
- 7.5** The maximum nominal allowed voltage of the (composed) main battery is 48 VDC.
- 7.6** The main battery may only be charged with the use of the installed solar panels.
- The first stage of the race may be started with a fully charged main battery.
 - All solar energy available during the race may be used for purposes of propulsion and /or to recharge the means of energy storage (e.g. battery, fly wheel, super capacitor, hot water, ice, etc.).
 - The solar panels may also be used in the mornings before the start of the next stage and in the evenings after the completion of the day's stage to use the available sunlight to charge the means of energy storage.
 - From the start of the first stage up to and including the end of the final stage, solar energy is the only energy allowed to recharge the means of energy storage.
 - It is also allowed to extract energy from the running engine with the use of short bursts of "regenerative braking" of the vessel.
 - The use of other forms of energy to charge the means of energy storage during the course of the race will result in disqualification.

- 7.7** It is allowed for a team to install extra batteries for safety reasons where it deems this necessary.
- This is however subject to the provision that the energy stored in those batteries is not used for propulsion.
 - If a participating team wishes to make use of such extra batteries, it is bound to submit a properly motivated application to that effect to the technical committee by no later than Step 4 of the design process.
 - The technical committee will then decide whether to allow this or not.
 - If the technical committee permits the use of extra batteries, this needs to be specifically mentioned at the technical inspection prior to the race, at which time it will be inspected.
 - Hand held navigation equipment powered by batteries is allowed as long as they are not electrically connected to the electrical system of the vessel.
- 7.8** All energy conducting parts must be fully insulated such as to prevent the occurrence of hazardous situations in the case of contact and exposure to water (for instructions on how to do this, please refer to the NEN/DIN standards for example).
- 7.9** The design of the electrical wiring and circuitry must be based on standard colour coding (NEN/DIN standards).
- 7.10** Participants are only allowed batteries that can be recharged electrically.
- The use of other types of batteries, such as mechanically charged batteries is not allowed. The use of fuel cells is not permitted.
 - Every team is responsible for its own batteries.
 - All batteries used in the race must be commercially available.
 - The batteries may under no circumstances be modified in any way whatsoever.
 - The participants must disclose all data related to the batteries no later than during Step 4 of the design process.
 - The specified battery data must at least include a detailed description of the type of battery to be used and the so-called "materials safety data sheet" as supplied by the manufacturer thereby providing the organisation with adequate information in case of an emergency
- 7.11** The batteries must be mounted in separate housings, such as to eliminate the risk of direct contact between the crew and the batteries and environmental pollution is prohibited.
- The purpose of the battery housing is to simplify the mounting of the battery in the vessel
 - The batteries and the fastening systems must be designed and manufactured such that they will remain fixed in their positions in the case of the vessel capsizing and thereby prohibiting environmental pollution.
 - The battery housing may be a separate housing or may be fully integrated in the hull.
 - The battery housing must prohibit, in case of damage of the batteries, that electrolyte flows into the hull.
 - The battery housing must therefore be manufactured out of materials resistant to the electrolyte of the batteries.
 - All batteries, both the main battery and the auxiliary batteries or the battery housing when not fully integrated in the hull, must be mounted to the hull using a band with a minimum width of 35 mm.
 - The use of Velcro is not permitted
 - Other suitable means of connection, as for instance used in cars, are allowed.
 - The minimum distance between the batteries and the crew is one metre.
 - It must be possible to easily seal the housing, as well as the electrical connections. This must be done in such a way that it is not possible to charge the battery with any other source than solar energy and that it is not possible to replace the battery without breaking the seal
 - All requirement with respect to mounting the batteries and their housing also apply to other means of energy storage.

- The housing must be fitted with a forced ventilation system with a minimum capacity of 0.3 m³/minute.
- The ventilation system must be operational at all times from the time the battery is electrically connected to the vessel (= when the mains switch of the electrical system is on).
- The outlet of the ventilation system must be located at a position behind the crew or in an alternative position that is suitably distant from the crew; all subject to the sole discretion of the technical committee.
- The battery ventilation system must be designed such that upward spray and rainwater will not be able to make direct electrical contact with the battery.
- The battery ventilation system must be powered by the main battery and/or the solar panels at all times.

7.12 All energy conducting cables must be designed in suitable dimensions to cope with the anticipated voltage and current.

Minimum requirements for copper cables in free air, according to the table

Crosssectional area (mm ²)	Allowed current (A)
1.5	20
2.5	27
4	36
6	46
10	62
16	80
25	105
35	125
50	155
70	195
95	235
120	270

7.13 All vessels must be fitted with an emergency mains switch to cut the power supply to the engine in emergency situations.

- The switch must be capable of breaking the electrical power supply under full load.
- The switch must be clearly marked as an engine switch
- The 'on' and 'off' positions must be clearly displayed.
- The lettering must be of a minimum height of 10 mm.
- It is allowed to use a relay in the switching system.
- In the case of the use of a relay, this relay must be suited for the application
- In the case of the use of a relay, it is allowed to use an additional battery to power the relay.

7.14 The electrical system must be provided with a fuse in serial connection with the main battery.

- The fuse may under no circumstances carry more than 200% of the expected power.
- The fuse must be mounted as close as possible to the main battery
- The rating of the fuse may not be higher than the allowed current in the thinnest wire in the relevant part of the electrical system.

7.15 The auxiliary system(s) must be provided with a fuse in serial connection with the auxiliary battery.

- The fuse may under no circumstances carry more than 125% of the expected power.

7.16 Participants are bound to use eye-protecting eye gear at all times when assembling, mounting and / or relocating the batteries and/ or when performing any other types of activities related to the batteries.

7.17 It must be possible to easily seal all electrical connections between the solar panels, the propulsion system and the energy storage systems.

- The participating teams must make sure that the necessary means are made available such that the organisation can apply the seals in a simple and fast way.
- The organization will apply seals to a number of these systems after the vessel has been technically approved.
- If a participant needs to break the seal, he or she is bound to notify the organization as soon as possible.
- The vessel is prohibited from racing from the moment the seal has been broken.
- The vessel may only return to the race once it has been subjected to a technical re-inspection and a new seal has been installed.

8. Appearance of the vessels

8.1 All participating vessels must show the registration number provided by the organisation.

- Therefore all vessels must mount a registration panel on the front deck. The maximum distance between the most forward threaded rod for mounting the panel and the bow is 500 mm.
- The front deck must have 4 threaded rods, size M6, suitably attached.
- The threaded rods must protrude 30 mm above the deck and be provided with two wide washers and one locking nut each.
- The mounting of the registration panel must be done according to the drawing.

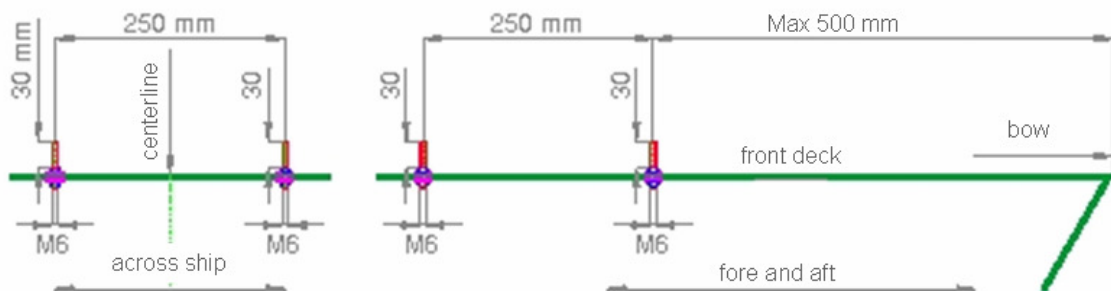

- The size of the registration panel is indicated in the drawing

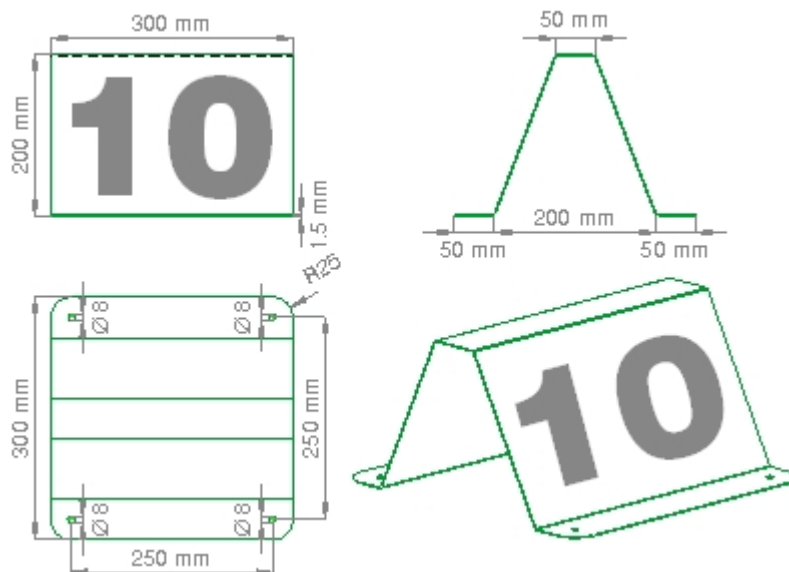

- The registration panel with the registration number will be provided by the organisation.
- The participating team will be held responsible for the acquiring of the registration panel showing the correct registration number.
- The registration number must be visible at all times and from all angles.

- The placement of the registration panel may not hinder the accessibility of the towing eye in the prow.
 - The registration panel will be sealed
- 8.2** Participants are allowed to finish the boat design with aesthetic embellishments of their own choice.
- Participants are also allowed to display their sponsors.
 - These displays may not be in conflict with sound moral standards whatsoever.
 - All subject to the sole discretion of the organization.
- 8.3** The registration panel will be fitted with a transponder for tracking and tracing during the race

9. Inspections

- 9.1** The organization is entitled to conduct inspections of the vessels at any time of its own choosing.
- The participants are bound to cooperate with such inspections.
- 9.2** All skippers and crew members are expected to have a minimum weight of 70 kg during the course of the race.
- To that end, all skippers and crew members will be weighed
 - The weighing will take place with the crew members wearing their bathing suits and life jacket.
 - In the case of a skipper or crew member weighing in at less than 70 kg, the weight of the ballast that he or she must carry throughout the race will be determined.
 - The applicable ballast and life jacket will be marked with a unique mark for the applicable skipper or crew member.
- 9.3** The technical committee will inspect all vessels for full compliance with the requirements prior to the start of the Challenge.
- All participants will be notified in advance of the time and location of the inspections.
 - The organization will invite the participants for an inspection.
 - During the inspection the participants are required to present their vessel in a race-ready condition.
 - Vessels that fail to comply with the applicable requirements will be disqualified from participation until the time they do come into compliance and this has been confirmed by means of a re-inspection.
 - All modifications to the vessel, made after the inspection, will be subject to re-inspection.
 - All vessels may be subjected to random additional inspections during the course of the race.
- 9.4** Participants are at all times responsible for the technical condition and safety of the vessel during the course of the race. Approval during the inspections will under no circumstances exempt participants of their due responsibilities.
- 9.5** The inspection set-up will be announced to all participants in advance by means of an inspection form that will be used during the inspection. Participants are asked to prepare themselves for the inspection by means of the inspection form, such that this will facilitate a smooth inspection.
- 9.6** If the vessel is able to sail faster than 20 km/h the skipper must be able to show his or her sailing permit to the organisation
- 9.10** Starting from the moment the technical inspection begins the vessels are not allowed to leave the paddock anymore.
- Leaving the paddock without prior permission of the technical committee will lead to disqualification.
 - No permission will have to be asked when a vessel is to be sailed to the sailing test, the prologue, the sprint or the starting point of a stage.